



An ITW Company

IQ Easy LP Static Neutralizing Bars

INSTALLATION AND OPERATING INSTRUCTIONS

TABLE OF CONTENTS

1. SAFETY WARNINGS	1
2. DESCRIPTION	3
3. SPECIFICATIONS	4
4. INSTALLATION	5
Unpacking	5
Mechanical Installation	5
Electrical Connections	8
Standalone	9
Set Up	10
5. OPERATION	13
Indicator Lights	13
With IQ Power Control Station	13
Standalone Operation	14
6. MAINTENANCE	14
Regular Cleaning	14
Removing Heavy Soil	14
Calibrate Bar	14
7. TROUBLESHOOTING	15
8. PARTS AND ACCESSORIES	16
9. WARRANTY AND SERVICE	17

1. SAFETY WARNINGS

PLEASE READ INSTRUCTIONS COMPLETELY BEFORE STARTING INSTALLATION

ALL INSTALLATION AND TROUBLESHOOTING OPERATIONS MUST BE PERFORMED BY QUALIFIED TECHNICAL PERSONNEL

The following safety guidelines must be observed in order to prevent physical injury and damage to objects or to the static neutralizing bar itself:

This instruction manual uses symbols to identify dangerous situations as follows:



WARNING – Electrical installation and repairs must be performed by a skilled electrical engineer according to the applicable national and local regulations.

AVERTISSEMENT – L'installation et le service électrique doivent être effectués par un électricien qualifié conformément aux réglementations locales et nationales.



WARNING – The device must only be powered by a Limited Power Source (LPS) or NEC Class 2 power supply.

AVERTISSEMENT – L'appareil ne doit être alimenté par une source d'alimentation limitée (LPS) ou NEC Class 2.



WARNING – The equipment must be properly grounded. Grounding is required to ensure safe and proper operation and to prevent electrical shocks upon contact.

AVERTISSEMENT – Le matériel doit être correctement mis à la terre. Mise à la terre est nécessaire pour assurer un fonctionnement sûr et correct et pour éviter les chocs électriques en cas de contact.



WARNING – Disconnect power before performing any work on the unit.

AVERTISSEMENT – Débranchez l'alimentation électrique avant toute intervention sur l'appareil.



WARNING – Keep the unit dry. Do not operate the unit in flammable or explosive environments.

AVERTISSEMENT – Gardez l'appareil au sec. Ne pas utiliser l'appareil dans des environnements inflammables ou explosifs.



CAUTION – The emitters are sharp and can cause physical injury.

ATTENTION – Les émetteurs sont pointues et peuvent causer des blessures.



NOTE – The high-voltage emitters (6 kV) are limited to a current of 30 μ A, which means that they are electrically safe to touch and shockproof.



NOTE – IQ Easy LP bars are designed to neutralize electrostatically charged surfaces only.



NOTE – During the ionization process a small amount of ozone is produced. The ozone concentration around the electrodes depends on a large number of factors, such as the amount of space around the static neutralizing bar and the air circulation. This means that no general value can be specified for the ozone concentration. For installations with poor ventilation it may be necessary to take precautions to ensure safe values of ozone concentration.



NOTE – If changes, adjustments, etc. are made without prior written consent or if repairs are performed using non-original parts, the equipment's warranty will no longer be valid.

2. DESCRIPTION

The IQ Easy LP is a static bar designed to neutralize electrostatically charged surfaces. The static bar is equipped with an integrated high-voltage power unit, ion emitters and status LEDs. They require a 24 VDC supply voltage to be provided via a 5-pin M12 connector.

The IQ Easy LP has been optimized for general applications including high web speeds exceeding 1600 feet-per-minute and/or distances from 1" to 5", and is available in lengths from 9.5" to 85", in increments of 2.4".

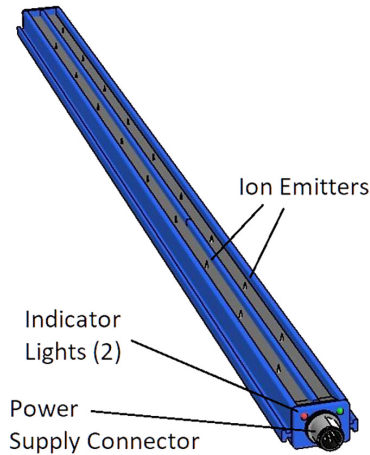

Figure 1: IQ Easy LP Static Bar Connector End

The IQ Easy LP also offers pulsed ionization suitable for bench type and equipment applications with low airflow or still air. In these applications the IQ Easy LP offers reasonable static elimination at moderate distances up to 48".

The 24 VDC supply voltage is converted inside the static neutralizing bar into positive and negative high voltage. The high voltage generates an electrical field at the emitters of the static bar, which causes the air molecules around the emitters to be converted into positive and negative ions. When an electrostatically charged material comes within operating distance of the static bar, ions from the static bar are exchanged with the charged material until the material is neutralized.

The (green) power LED indicates when the static neutralizing bar is in operation, is in standby or when the bar receives commands. The (red) alarm LED indicates if the static bar is overloaded or communications is interrupted.

3. SPECIFICATIONS

Electrical	
Input Voltage	24 VDC
Input Current	0.75A (max)
Input Connection	5-pin M12 (A-coded) male receptacle
Output Voltage	6 kV
Output Current (to Ground)	30 μ A per emitter (max)
Indicators (2)	Green (steady) = Operation Green (flashing) = Standby Green (flickering) = Communication Red (steady) = Fault Red (blinking) = Communication Failure
Environment	
Intended Use	Industrial, indoor use only
Compliance	RoHS
Ingress Protection Class	IP66
Operating Temperature	55°C [131°F] (max)
Operating Humidity	70% RH, no dewing permissible (max)
Target Material Speed	>488 m/min [1600 fpm] (distant dependent)
Operating Distance	25-125 mm [1-5"] (conveyed material/web) 300-1200 mm [1-4'] (stationary/slow moving material)
Mechanical	
Length	240-2160 mm [9.45-85.04"]
Width	34 mm [1.34"]
Height	19.1 mm [0.75"]
Enclosure	Glass fiber reinforced polycarbonate
Compliance	RoHS Compliant

4. INSTALLATION



WARNING – Electrical installation and repairs must be performed by a skilled electrical engineer according to the applicable national and local regulations.

AVERTISSEMENT – L'installation et le service électrique doivent être effectuées par un électricien qualifié conformément aux réglementations locales et nationales.



WARNING – The equipment must be properly grounded. Grounding is required to ensure safe and proper operation and to prevent electrical shocks upon contact.

AVERTISSEMENT – Le matériel doit être correctement mis à la terre. Mise à la terre est nécessaire pour assurer un fonctionnement sûr et correct et pour éviter les chocs électriques en cas de contact.



WARNING – Disconnect power before performing work on the unit.

AVERTISSEMENT – Débranchez l'alimentation électrique avant toute intervention sur l'appareil.



WARNING – The device must only be powered by a Limited Power Source (LPS) or NEC Class 2 power supply. An LPS certified power supply has a limited output power, which means that it always generates a safe output voltage.

AVERTISSEMENT – L'appareil ne doit être alimenté par une source d'alimentation limitée (LPS) ou NEC Class 2.

Unpacking

Carefully remove all equipment from its carton and inspect the contents:

- Check that the details on the packing slip correspond to the details of the product received.
- Check that the equipment is free from damage.
- If any damage has occurred during shipment, notify the local carrier at once. A report should also be forwarded to Simco-Ion, 2257 North Penn Road, Hatfield, PA 19440. See Section 9 of this manual for Return Shipment information.

Mechanical Installation



NOTE – Conductive machine parts in the vicinity of the static neutralizing bar have a detrimental influence on its operation. For optimum results, the static bar must be installed as per Figure 4.

1. Directly in front of where static electricity causes problems.
2. At an optimum distance from the material to be neutralized, 2-5" [50-125 mm]
3. Emitters must face the material to be neutralized.

4. DO NOT mount the bar over a roller or where the material to be neutralized is in contact with any other surface.

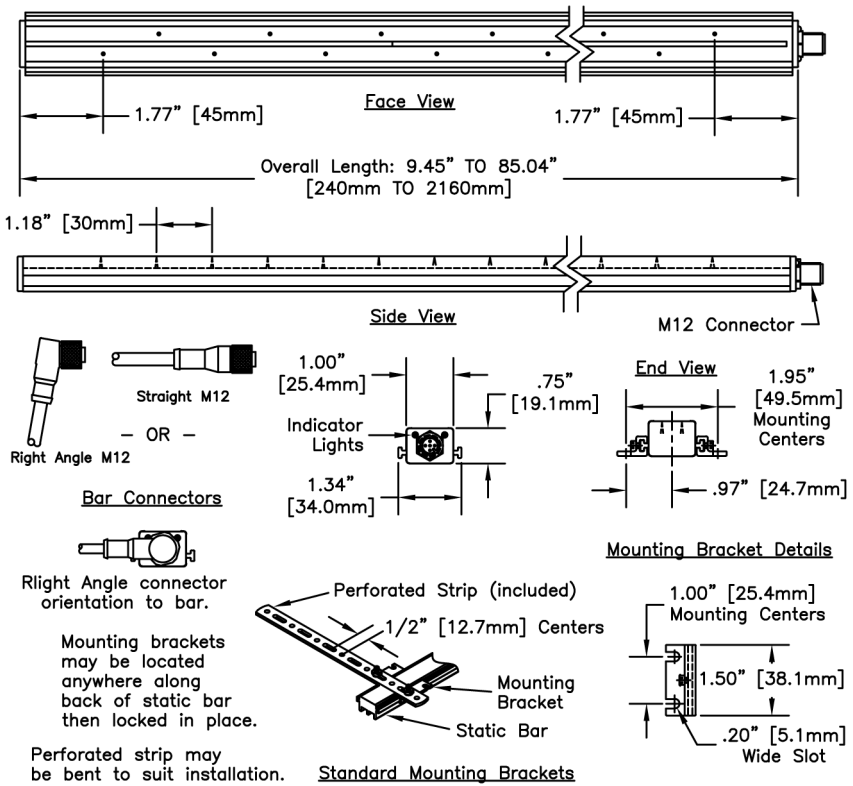

Figure 2: IQ Easy LP Static Bar Dimensions

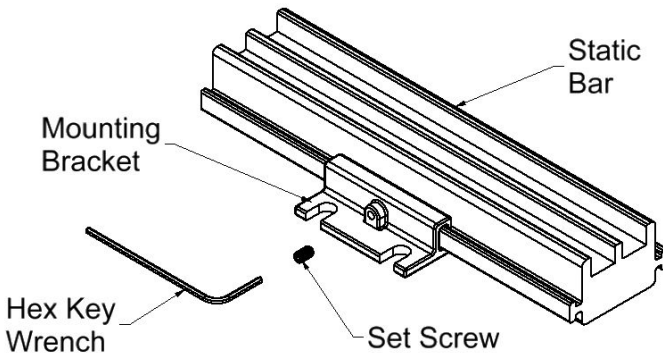

Figure 3: IQ Easy LP Static Bar Mounting

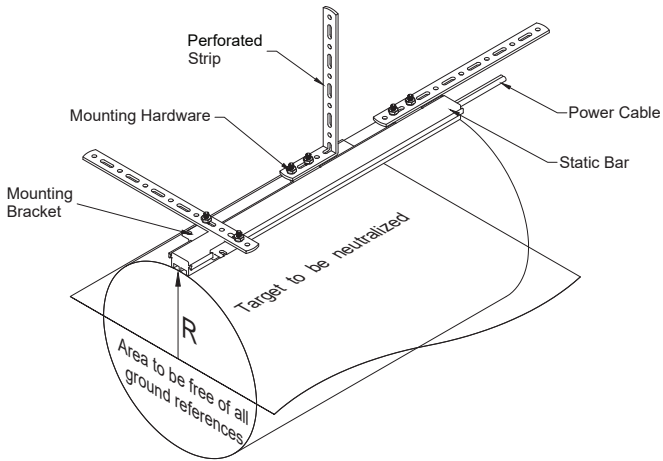

Figure 4: IQ Easy LP Static Bar Positioning - Conveyed Material/Web

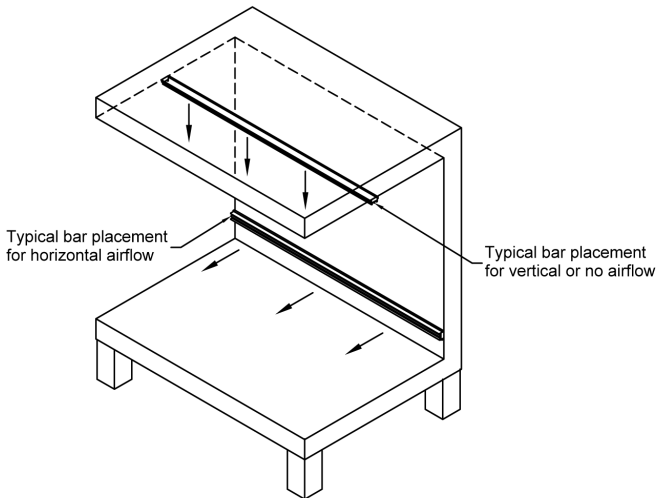

Figure 5: IQ Easy LP Static Bar Positioning - Stationary/Slow Moving Material

4. Attach static neutralizing bar using fasteners supplied. See Figures 3 and 4.
5. Lock static bar in brackets by manually tightening screws in the brackets.
6. Connect M12 connector of power cable to static bar and route power cable to power supply safely.

Electrical Connections



WARNING – Electrical installation must be performed by a skilled electrical engineer according to applicable national and local regulations.

AVERTISSEMENT – L'installation et le service électrique doivent être effectués par un électricien qualifié conformément aux réglementations locales et nationales.



WARNING – IQ Easy LP Bars must be properly grounded.

AVERTISSEMENT – Le matériel doit être correctement mis à la terre.



WARNING – Remove power before working on IQ Easy LP Bars.

AVERTISSEMENT – Débranchez l'alimentation électrique avant toute intervention sur l'appareil.



WARNING – IQ Easy LP Bars must only be powered by a Limited Power Source (LPS) or NEC Class 2 power supply.

AVERTISSEMENT – L'appareil ne doit être alimenté par une source d'alimentation limitée (LPS) ou NEC Class alimentation 2.



NOTE – IQ Easy LP Bars will not function properly if emitters are covered.

For safe and reliable connection to 24 VDC power, IQ Easy LP Bars are provided with an appliance inlet for connection of a detachable power supply cord. There are several methods of making this electrical connection:

For Connection to IQ Power Control Station

1. Remove protective cap from static bar inlet connector.
2. Place the appropriate M12 connector on cable against static bar connector and rotate connector until keyed connectors align. Press connectors together and turn coupling nut clockwise to thread it on. Finger-tighten coupling nut until connector is fully seated.
3. Connect cable to control station.
 - a. **M12 to M12 Cable (recommended)** – Place the other M12 connector on cable against DEV1 thru DEV6 connector and rotate the connector until keyed connectors align. Press connectors together and turn knurled coupling nut clockwise to thread it on. Finger-tighten coupling nut until connector is fully seated.
 - b. **M12 to RJ-45 Cable** – Connect RJ-45 plug on other end of cable to connector 1 thru 10, labeled POWER & COMM, on control station.
4. Route cable away from any moving machine parts and secure cable to prevent damage.

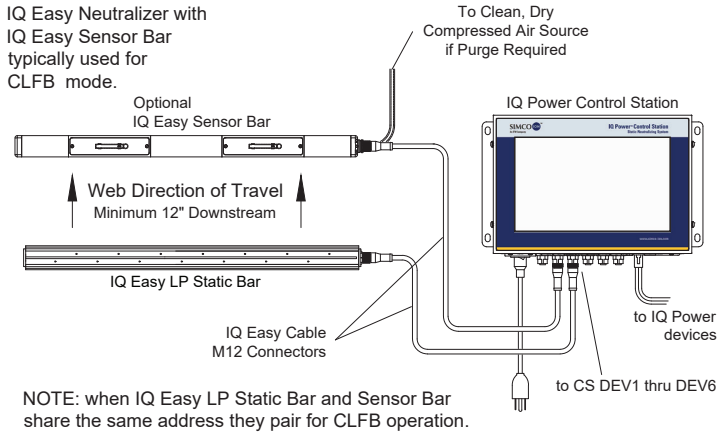

M12 to M12 Connector Cable Construction



Alternate cable that may be used to connect IQ Easy devices to CS 1 thru 10 POWER & COMM.

RJ-45 to M12 Connector Cable Construction

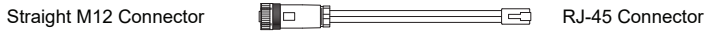

See Section 8 Parts and Accessories for available cable lengths and part numbers.

Figure 6: Typical IQ Easy LP Connections

Standalone

The IQ Easy LP Static Neutralizing Bar may be operated without a control station. In this case, the IQ Easy LP Static Bar will enter Standalone operating mode. In Standalone Mode, the IQ Easy LP Static Bar operates in Fixed mode ionization with a factory balance setting.

IQ Easy LP Wiring

Examples of typical wiring.

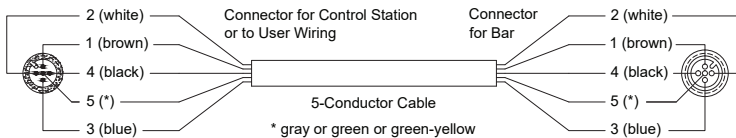

Figure 7: IQ Easy LP Static Bar Control Station Wiring

The wiring color code shown in Figure 6 is typical for 5-pin M12 A-coded connection cables used with the Control Station.

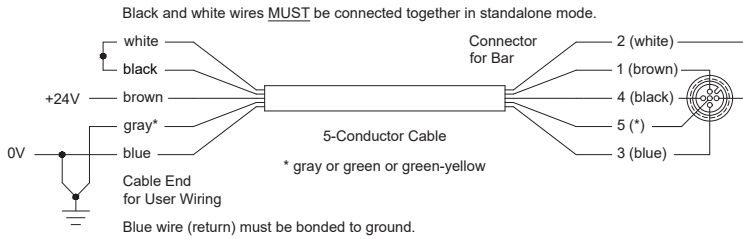

Figure 8: IQ Easy LP Static Bar Standalone Wiring



NOTE – Electrical connections shall be made by qualified personnel in accordance with national and local electric codes using only Recognized connectors appropriate for 22 AWG wires and rated for no less than 24 VDC 4A.



WARNING – For personal protection, and to ensure proper function, the GRAY* and BLUE wires must both be connected to ground.

AVERTISSEMENT – Pour votre sécurité, et pour assurer un bon fonctionnement, les câbles GRIS* et BLEU doivent tous deux être connectés à la terre.

* The GRAY wire may appear GREEN or GREEN/YELLOW on some models. Le GRIS du câble peut apparaître VERT ou VERT/JAUNE sur certains modèles.

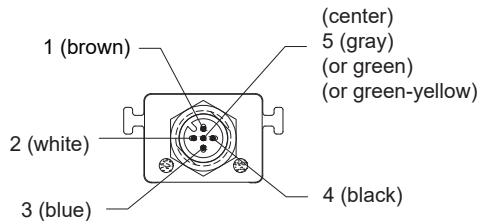

Figure 9: IQ Easy LP Static Bar Connector Pin-Out

The pin-out connections are:

- | | |
|------------------|--|
| 1 (brown) +24V | 4 (black) COMM B |
| 2 (white) COMM A | 5 (gray / green / green-yellow) ground |
| 3 (blue) ground | |

Set Up

The IQ Easy LP offers various modes of operation suitable for fast moving conveyed materials or webs, it also offers pulse mode for stationary and slow moving materials at a moderate distance. In fast moving applications the bar is located close to the target and the electrostatic attraction of ions from the bar is the primary method of static neutralization. In pulse mode ion delivery is achieved from environmental airflow or by the bar itself, driving the ions over moderate distance for static neutralization.

A variety of information can be checked, and operating parameters set, for the IQ Easy LP Static Neutralizing Bar through the IQ Power Control Station via the static bar page / tab. Tap on the device icon for the static bar to access these pages.



NOTE – Availability of operating parameters depends on operating mode selected.

To edit or select an operating parameter, tap on the pencil icon to the right of the parameter description.

Device Name: A user editable name to identify the specific static bar (14 character).

Bar Type: A fixed description for the device type.

High Voltage: Turns the bar HV power supply on/off. Turning the bar HV power off places the bar in standby, the green indicator on end of bar will begin to flash.

Total Ion Output: Displays the ionization level, in percent, where Bar Calibration = 100% and the ionization level in terms of microamps for both positive and negative ionization.

Operation Mode: A user selectable operating mode for the static bar (Fixed, Auto-Tune, CLFB, Balance, Manual, Pulse).

- **Fixed** – Balanced standard operation (default factory setting). Fixed provides standard operation, with output voltage regulation.
- **Auto-Tune – Enhanced operation.** This mode includes the current monitoring found in Fixed mode, plus automatic compensation that takes into account web speed, bar type, bar mounting distance and measured ion current to optimize static neutralization performance. In order to successfully invoke Auto-Tune, certain operating parameters must be defined:
 - Web Speed will have to be entered by the user.
 - Mounting Distance will have to be entered by the user. It is the distance between the face of the static neutralizing bar and the web, or material to be neutralized.
- **CLFB** – Closed-loop Feed Back, best control of ion balance, requires pairing with a downstream IQ Easy Sensor Bar. The sensor bar detects any voltage imbalance on the web, or material to be neutralized, then transmits this information to the static neutralizing bar. The static bar makes incremental changes to the balance setting until downstream charges are minimized.
- **Balance** – Allows manual control of ion balance. Balance mode features two levels of adjustment; Coarse and Fine, giving precision control to ion output. Ion output or performance is not affected in high charge applications.
- **Manual** – Allows manual control of the ion output. Manual mode includes voltage regulation and current monitoring found in the standard mode, plus

manual control of the ion output ratio. This mode of operation would only be selected where the web, or material to be neutralized, exhibited extreme and consistent charging of one polarity.

- **Pulse** – Provides pulsed ionization where the Pulse Time and Pulse Overlap may be adjusted. Pulse Mode typically provides static neutralization at moderate distance in stationary and slow moving material environments.

Pulse Time – The time, in seconds, the bar will emit ions of a given polarity. In general longer pulse times provide quicker static discharge where the distance to bar is long and the airflow is low. Shorter pulse times provide better ion balance when distance to bar is short and airflow is high.

Pulse Overlap – The percentage alternating pulses overlap. Overlap reduces peak offset voltages. Low, or no Overlap would typically only be used in very low or still airflow.

Balance: A ratio of input power supplied to the high voltage power supplies that related to ion balance. In Fixed, Auto-Tune and CLFB modes this is a display only and non-editable. The Balance may only be user adjusted in the Balance or Manual mode.

Mounting Distance: A user entered dimension, the spacing between the face of the static neutralizing bar and web (surface being neutralized). Typical mounting distance is 1" (25 mm) to 5" (125 mm). The factory default mounting distance is 2" (50 mm).



NOTE – This information (Mounting Distance) **MUST** be correct. It is used by the static neutralizing bar when in Auto-Tune mode. If this information is not correct, the static bar may not operate properly when in the Auto-Tune mode.

Web Speed – A user entered value used in the Auto-Tune Mode only.

Sensor Quantity – The number of sensors found on the sensor bar.

Overall Sensor Avg – The average voltage reported by all sensor modules on a static sensor bar.

Feedback Sensor Avg – The feedback voltage for use in CLFB control. This is determined by using the Sensors for Feedback, a user adjustable operating parameter.

Warning Setpoint – The web voltage level at which the sensor bar will set a “Warning” and illuminate the yellow indicator light on the end of the bar. The factory default Value is 5 kV, however this value may be user adjusted.

Alarm Setpoint – The web voltage level at which the sensor bar will set an “Alarm” and illuminate the red indicator light on the end of the bar. The factory default value is 20 kV, however this value maybe user adjusted.

Web Voltage Sensor 1,2,3... – The voltage level reported by a given sensor module.

Device Version – The firmware revision in the device.

Device Locator Utility – Causes the indicator lights on the deceive to flicker for a brief time to aid in verifying location of a given device.

Alarm Test Utility – Causes an alarm output to aid in checking/troubleshooting alarm sensing connections.

Calibration, Date, Time – Displays the time and date of last calibration and allows for calibration of the bar (not available in Pulse Mode).

Clean Bar Threshold – The ion output level in percent for activating the Clean Bar Alarm. The factory default value is 50%, however the Clean Bar Threshold is user adjustable. Clean Bar Threshold/Clean Bar Alarm is not available in Pulse Mode operation.

Paired Sensor – The specific sensor bar used with a static neutralizing bar in closed-loop feedback (CLFB) mode. The static neutralizing bar **MUST** be upstream (before) the sensor bar.

Pairing is controlled by matching the sensor bar address to the IQ Easy LP static neutralizing bar address. In either case, the sensor will appear as a tab on the neutralizer device page on the Control Station Display.

5. OPERATION

The IQ Easy LP Static Neutralizing Bar performs a self-test which includes illumination of the two (green and red) indication lights on the static bar. The self-test and power up of the high voltage supplies occurs before ionization is produced at the emitters. This takes approximately five seconds on application of power.

Indicator Lights

Two indicator lights are located on the connector end of the static bar: green and red.

Green

- A steady green light indicates the static bar is powered and active
- A flashing green light indicates the HV power supplies are off and the bar is in standby
- A brief rapid flickering of the green indicator light indicates the static bar has received a command from the Control Station

Red

- A steady red light indicates an internal fault in the static bar
- A blinking red indicator light indicates a communication failure

With IQ Power Control Station

The operation of the IQ Easy LP Static Neutralizing Bar can be controlled through an IQ Power Control Station. In operation, a device icon appears on the Home Page. Tapping on the device icon opens a Summary page containing information about the IQ Easy LP static neutralizing bar, and static sensor bar (if paired). More detailed information and user editable parameters are available through device tabs. For information see the Set Up section in this document.



NOTE – If the static bar presents a premature Clean Bar alarm, this may indicate the need to calibrate the static bar; see Maintenance for details.



NOTE – Newly installed IQ Easy LP Static Neutralizing Bars may require calibration; see Maintenance section for details. Machine frames adjacent the bar, rollers, etc. may interfere with the ionization process. If the Ionization Output of a new bar is less than 80%, this may indicate the need to calibrate the static bar.

Standalone Operation

If an IQ Easy LP Static Neutralizing Bar is energized without a control station it will detect the lack of digital communication. In this case it enters the Standalone mode and switches the communication wiring off.

In Standalone mode the IQ Easy LP Static Bar defaults to Fixed mode for the ionization. Fixed provides standard operation, with output voltage regulation and a factory balance setting. Normal operation is indicated by a green light on the end of the bar. If the red indicator lights the bar has an internal fault and service is required. Standalone mode does not offer a clean bar alarm.

6. MAINTENANCE



WARNING – Remove power before working on IQ Easy LP Bars.

AVERTISSEMENT – Débranchez l'alimentation électrique avant toute intervention sur l'appareil.

Regular Cleaning

Clean the emitter points and the static neutralizing bar regularly with a stiff bristle, non-metallic brush.



WARNING – The emitters are sharp and can cause physical injury.

AVERTISSEMENT – Les émetteurs sont pointues et peuvent causer des blessures.

Removing Heavy Soil

Clean the static neutralizing bar using isopropyl alcohol. Be sure to allow the static bar to dry completely before applying power.

Calibrate Bar



NOTE – Calibration should be performed when the system is first installed and may be performed after the static bar has been cleaned and the system verified as operating correctly. Calibration is, however, locked out in Pulse Mode.

If the system is new, it may be necessary to perform an initial calibration. The initial calibration sets the relative nominal ion output for the system. Calibration should only be performed on IQ Easy LP Static Neutralizing Bars that are new or just cleaned and known to be in proper working order.

During calibration the target to be neutralized (web, film, etc.) may remain in place, but **MUST NOT BE MOVING**. If the web is moving past the static bar (e.g. the machine is in operation) the calibration will be faulty.

The system should be “on” and in the operating mode. On the IQ Power Control Station tap on the device icon for the IQ Easy LP static bar. Tap on the Neutralizer tab. Tap on the page forward arrow to get to the last page. Find the IQ Easy LP Bar Calibration line and tap on the pencil. Enter the Control Station password at the prompt (Note: the factory default password is “PASSWORD”.) Tap on “yes” at “Calibrate IQ Easy LP Bar?”.

During calibration the system output will be cycled and the indicator lights on the static bar end will flash. Calibration takes as long as 5 seconds. The indicated ionization output will be high (90% to 100%).

The calibration data is stored in non-volatile memory in the IQ Easy LP bar and used on subsequent power ups.

7. TROUBLESHOOTING



WARNING – Remove power before working on IQ Easy LP Static Neutralizing Bars.

AVERTISSEMENT – Débranchez l’alimentation électrique avant toute intervention sur l’appareil.

Signal	Problem	Cause	Solution
LEDs on bar do not light	No high voltage at emitters	No supply voltage	Apply power to Control Station & turn on Reconnect IQ Easy LP bar to different DEV connector on Control Station
		Wiring problem	Check AC adapter (if operating standalone) for input and output power Replace cable with known good cable
Red LED on bar is lit	Internal fault in bar	Various	Cycle power to bar to see if fault clears (if fault does not clear, return bar to factory for repair)
Red LED on bar is blinking	Communication failure	Various	Cycle power to bar to see if fault clears Change connection at Control Station Replace cable with known good cable
		Wiring problem	If multiple device have communication failure; turn off Control Station, disconnect all devices, reconnect one-by-one to isolate problem If fault does not clear, return bar to factory for repair
Green LED on bar is flashing	No high voltage at emitters	Bar is in standby	Change bar HV setting at control station from off to on

8. PARTS AND ACCESSORIES

Item	Part No.
M12 to M12 Cables for connecting Static Bar to Control Station with straight connector at bar end 1.5 meter (4.9 foot) 5 meter (16.4 foot) 10 meter (32.8 foot) 20 meter (65.6 foot) 30 meter (98.4 foot)	 5051939 5051791 5051792 5051793 5051794
M12 to RJ-45 Cables for connecting Static Bar to Control Station (1 thru 10) with straight connector at bar end 4.57 meter (15 foot) 9.14 meter (30 foot)	 5051840 5051844
M12 Cables with flying leads for Standalone Mode with straight connector at bar end 5 meter (16.4 foot) 10 meter (32.8 foot)	 5051606 5051737
Connector for Standalone Mode - Provides 500 mm (20 inch) flying leads for user connection (use with M12 to M12 cable)	4612473
AC Adapter for Standalone Mode, does not provide output 5 meter (16.4 foot) cable w/ straight connector for bar, 120 VAC 5 meter (16.4 foot) cable w/ straight connector for bar, 230 VAC	 5051608 5051609
Mounting Kit (includes mounting bracket, perf strip and hardware)	5051918
Static Bar Cleaning Brush	4670204

9. WARRANTY AND SERVICE

This product has been carefully tested at the factory and is warranted to be free from any defects in materials or workmanship. Simco-Ion will, under this warranty, repair or replace any equipment that proves, upon our examination, to have become defective within one year from the date of purchase.

The equipment being returned under warranty should be shipped by the purchaser to Simco-Ion, 2257 North Penn Road, Hatfield PA 19440, transportation prepaid and insured for its replacement cost. Prior to returning any goods for any reason, contact Simco-Ion Customer Service at (215) 822-6401 for a Return Authorization Number. This number must accompany all returned items.

This warranty does not apply when the equipment has been tampered with, misused, improperly installed, altered, has received damage through abuse, carelessness, accident, connected to improper line voltage, or has been serviced anyone other than an authorized factory representative.

The warranty does not apply when Simco-Ion parts and equipment have been energized by other than the appropriate Simco-Ion power supply or generator, or when a Simco-Ion power supply or generator has been used to energize other than Simco-Ion parts and equipment. Simco-Ion makes no warranty, expressed or implied, nor accepts any obligation, liabilities, or responsibility in connection with the use of this product other than the repair or replacement of parts stated herein.

Information in this publication supersedes that in all previous published material. Specifications are subject to change without notice.

Simco-Ion

2257 North Penn Road
Hatfield, PA 19440

(215) 822-6401

(800) 203-3419

www.simco-ion.com

customerservice@simco-ion.com

© 2020 Simco-Ion. Printed in the U.S.A.